



Leather — Physical and mechanical tests — Determination of flexural properties

Cuir — Essais physiques et mécaniques — Détermination des propriétés de flexion

ICS 59.140.30

ISO/CEN PARALLEL PROCESSING

This draft has been developed within the European Committee for Standardization (CEN), and processed under the **CEN-lead** mode of collaboration as defined in the Vienna Agreement.

This draft is hereby submitted to the ISO member bodies and to the CEN member bodies for a parallel five-month enquiry.

Should this draft be accepted, a final draft, established on the basis of comments received, will be submitted to a parallel two-month approval vote in ISO and formal vote in CEN.

This draft International Standard is submitted to all ISO member bodies for voting, as a standard prepared by an international standardizing body in accordance with Council Resolution 42/1999. The proposer, *Physical Tests Commission of the International Union of Leather Technologists and Chemists Societies (Commission IUP, IULTCS)*, has been recognized by the ISO Council as an international standardizing body for the purpose of Council Resolution 42/1999.

To expedite distribution, this document is circulated as received from the committee secretariat. ISO Central Secretariat work of editing and text composition will be undertaken at publication stage.

Pour accélérer la distribution, le présent document est distribué tel qu'il est parvenu du secrétariat du comité. Le travail de rédaction et de composition de texte sera effectué au Secrétariat central de l'ISO au stade de publication.

THIS DOCUMENT IS A DRAFT CIRCULATED FOR COMMENT AND APPROVAL. IT IS THEREFORE SUBJECT TO CHANGE AND MAY NOT BE REFERRED TO AS AN INTERNATIONAL STANDARD UNTIL PUBLISHED AS SUCH.

IN ADDITION TO THEIR EVALUATION AS BEING ACCEPTABLE FOR INDUSTRIAL, TECHNOLOGICAL, COMMERCIAL AND USER PURPOSES, DRAFT INTERNATIONAL STANDARDS MAY ON OCCASION HAVE TO BE CONSIDERED IN THE LIGHT OF THEIR POTENTIAL TO BECOME STANDARDS TO WHICH REFERENCE MAY BE MADE IN NATIONAL REGULATIONS.

RECIPIENTS OF THIS DRAFT ARE INVITED TO SUBMIT, WITH THEIR COMMENTS, NOTIFICATION OF ANY RELEVANT PATENT RIGHTS OF WHICH THEY ARE AWARE AND TO PROVIDE SUPPORTING DOCUMENTATION.

PDF disclaimer

This PDF file may contain embedded typefaces. In accordance with Adobe's licensing policy, this file may be printed or viewed but shall not be edited unless the typefaces which are embedded are licensed to and installed on the computer performing the editing. In downloading this file, parties accept therein the responsibility of not infringing Adobe's licensing policy. The ISO Central Secretariat accepts no liability in this area.

Adobe is a trademark of Adobe Systems Incorporated.

Details of the software products used to create this PDF file can be found in the General Info relative to the file; the PDF-creation parameters were optimized for printing. Every care has been taken to ensure that the file is suitable for use by ISO member bodies. In the unlikely event that a problem relating to it is found, please inform the Central Secretariat at the address given below.

Copyright notice

This ISO document is a Draft International Standard and is copyright-protected by ISO. Except as permitted under the applicable laws of the user's country, neither this ISO draft nor any extract from it may be reproduced, stored in a retrieval system or transmitted in any form or by any means, electronic, photocopying, recording or otherwise, without prior written permission being secured.

Requests for permission to reproduce should be addressed to either ISO at the address below or ISO's member body in the country of the requester.

ISO copyright office
Case postale 56 • CH-1211 Geneva 20
Tel. + 41 22 749 01 11
Fax + 41 22 749 09 47
E-mail copyright@iso.org
Web www.iso.org

Reproduction may be subject to royalty payments or a licensing agreement.

Violators may be prosecuted.

Contents

Page

Foreword	iv
1 Scope	1
2 Normative References.....	1
3 Terms and definitions	1
4 Principle	2
5 Apparatus	2
6 Sampling and sample preparation.....	4
7 Test procedure.....	4
8 Test report.....	4
Annex A (informative) Sources of apparatus	6

Foreword

ISO (the International Organization for Standardization) is a worldwide federation of national standards bodies (ISO member bodies). The work of preparing International Standards is normally carried out through ISO technical committees. Each member body interested in a subject for which a technical committee has been established has the right to be represented on that committee. International organizations, governmental and non-governmental, in liaison with ISO, also take part in the work. ISO collaborates closely with the International Electrotechnical Commission (IEC) on all matters of electrotechnical standardization.

International Standards are drafted in accordance with the rules given in the ISO/IEC Directives, Part 2.

The main task of technical committees is to prepare International Standards. Draft International Standards adopted by the technical committees are circulated to the member bodies for voting. Publication as an International Standard requires approval by at least 75 % of the member bodies casting a vote.

Attention is drawn to the possibility that some of the elements of this document may be the subject of patent rights. ISO shall not be held responsible for identifying any or all such patent rights.

ISO 14087 was prepared by the Physical Tests Commission of the International Union of Leather Technologists and Chemists Societies (IUP Commission, IULTCS) in collaboration with the European Committee for Standardisation (CEN) Technical Committee CEN/TC 289, *Leather*, the secretariat of which is held by UNI, in accordance with the agreement on technical co-operation between ISO and CEN (Vienna Agreement).

Leather — Physical and mechanical tests — Determination of flexural properties

1 Scope

This International Standard describes a test method for the determination of the bending force of leather.

2 Normative References

The following referenced documents are indispensable for the application of this document. For dated references, only the edition cited applies. For undated references, the latest edition of the referenced document (including any amendments) applies.

ISO 2418, *Leather – Chemical, physical and mechanical and fastness tests - Sampling location*

ISO 2419, *Leather - Physical and mechanical and fastness tests – Sample preparation and conditioning*

ISO 2589, *Leather - Physical and mechanical tests – Determination of thickness*

3 Terms and definitions

For the purposes of this standard, the following terms and definitions apply.

3.1

bending force

force exerted by the specimen on the measuring bar at a specified bending angle, bending length and bending rate

3.2

bending angle

angle at which the bending force is measured

3.3

bending length

length around which the specimen is bent. Distance between the clamping device of the specimen and the bar onto which the force of the specimen is transferred

3.4

bending rate

rate of bending of the specimen in °/s

3.5

width-related bending force

bending force related to the specimen width, in N/mm

**3.6
compression and extension bending**

"Compression" is when the side facing the passenger compartment (grain side, coating) is compressed during bending. "Extension" is when the side facing the passenger compartment (grain side, coating) is extended during bending

4 Principle

The bending force is determined based on the bar method / two-point method. In this method, the specimen is clamped in a rotating fixture. During the rotation, the specimen exerts a force onto a bar. The force acting at a specified angle is measured.

5 Apparatus

5.1 Device for determining the bending stiffness according to the bar method (two-point method) with the following requirements: The specimen shall be able to be clamped vertically. The clamping jaws shall have a depth of (35 ± 1) mm and a minimum width of at least 30 mm (see figure 1). The clamping device shall enable parallel clamping with an even pressure distribution on the specimen. It shall move smoothly and allow tightening with a torque wrench. The clamping device shall allow for affixing the specimen without it touching the bar in its initial position

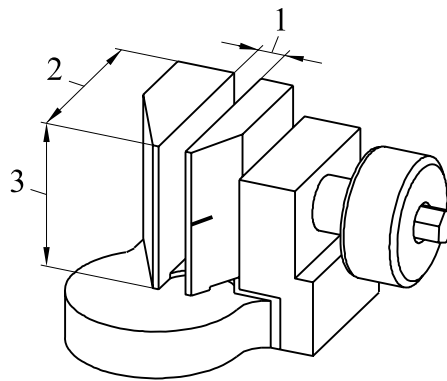

Key

- 1 - Aperture > 6 mm
- 2 - Clamping jaws
- 3 - Width 30 mm minimum

Figure 1 — Clamping jaws

The clamping device is pivoted. The pivot point is located exactly at the front edge of the fixed clamp (deviation of $\pm 0,1$ mm) (see figures 2 and 3). Rotation shall be possible within the range of 1 to 91° with a maximum deviation of 0,1°. The rotational speed shall be able to be adjusted up to 10°/s with an accuracy of 0,1°/s. At maximum load, the maximum deviation of the rotational speed allowed is 0,1%.

The rotation of the specimen causes it to be pressed against a vertical bar. The bar is connected to a load cell that allows measurement of forces up to 10 N (optionally, 1 N for very flexible materials) with a minimum resolution of 0,1 % and a maximum deviation of 0,1 %. The bar design shall exhibit a sharp edge ($R = 0,05 \pm 0,01$ mm) and a width of at least 30 mm. The weight of the bar shall not influence the measured value.

The distance between the bar and the pivot point shall be adjustable in a range from 0,1 to 50 mm with an accuracy of 0,1 mm. At the start of the measurement, the specimen is moved towards the bar until contact is made and a defined preliminary force is reached. This preliminary force shall be able to be adjusted with an accuracy of 1 mN. When the preliminary force is reached, the measurement shall start, i.e., angle = 0° and

force = preliminary force setting. The evaluation unit shall ensure measurement of the force at one or more previously defined angles. These angles shall not be identical to the maximum angle of rotation. The measuring apparatus shall ensure that all significant parameters (force, length, speed) can be checked, calibrated and restored. It is recommended that the measured data (raw data and parameter settings) are able to be electronically archived.

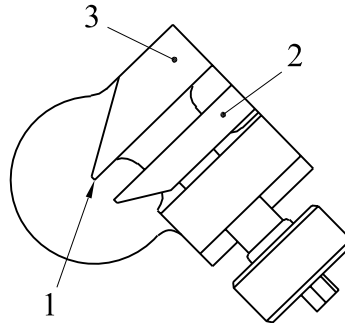

Key

- 1 - Fixed clamp
- 2 - Pivot point
- 3 - Moving clamp

Figure 2 — Pivot point, tolerance 0,003 mm

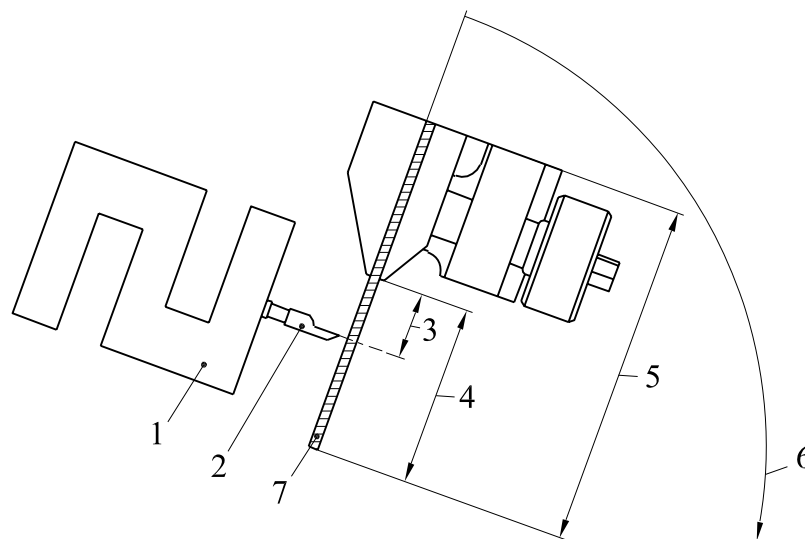

Key

- 1 – Load cell
- 2 – Vertical metering bar
- 3 – Bending length – adjustable
- 4 – Free sample length
- 5 – Sample length
- 6 – Rotating direction
- 7 – Sample

Figure 3 — Clamping jaws with specimen, load cell and bar with sharp edge

NOTE An example of a commercial source for a suitable device is given in Annex A

5.2 Torque wrench suitable for a range from 0,05 to 0,2 Nm with an accuracy of 0,01 Nm.

5.3 Press knife according to ISO 2419 for the corresponding specimen size

6 Sampling and sample preparation

Sampling is conducted according to ISO 2418 if possible and conditioning according to ISO 2419. The dimensions of the specimens shall be taken from the relevant parameter sets, (see 7.1). Other dimensions are permissible but shall be indicated in the test report. The sample is taken parallel with and perpendicular to the backbone. Other sampling angles (e.g., diagonal) are also permissible and details shall be given in the test report. If the orientation of the backbone is not known, each specimen shall be taken in two directions running perpendicular to each other. At least three specimens shall be used in each direction.

Both extension and compression bending of the grain / coated side is possible. For the extension bending test, the leather specimen shall be inserted so that the bar will press on the grain/coated side. To make the compression bending test the leather specimen shall be inserted so that the bar will press on the flesh/back side.

If both the compression and extension bending tests are to be conducted on the leather sample an additional three specimens shall be used for each sampling direction.

7 Test procedure

7.1 Each specimen shall be tested only once and shall then be discarded. The specimen shall be carefully clamped into the test device such that the free-standing part of the specimen corresponds to the clamping length specified in the table. A torque wrench with a setting of 0.08 Nm shall be used to tighten the clamping jaws. Then, the test shall be started with one of the specified parameter sets specified in the table below. The measurement starts at 0° when the specified preliminary force is reached. The measured forces shall be recorded at the required bending angle.

Three different set of parameters can be used. If no set is specified, use set A as standard set.

	Set of parameter		
	A (Standard)	B	C
bending length [mm]	5	10	15
free clamping length [mm]	15	20	25
measurement in bending angle of [°]	60	60	60
bending up to an angle of °	63	63	63
bending rate [°/s]	1,5	1,5	1,5
bending rate up to preliminary force [°/s]	1,5	1,5	1,5
dimensions of sample (width x length) [mm]	30 x 50	30 x 55	30 x 60
preliminary force [mN]	3	3	3

Unless otherwise specified, calculate the mean value for all sampling directions (using all individual values). For measurements testing both bending parameters of the leather (compression and extension), mean values for each bending parameter shall be calculated. The mean values shall be given in the test report.

7.2 Measure the thickness of the leather in accordance to ISO 2589. The same specimens used for the measurement of flexural properties can be used. In this case thickness shall be measured after the measurement of flexural properties.

8 Test report

The test report shall include the following:

- a) reference to this International Standard (i.e. ISO 14087);
- b) a description of the test specimen(s)
- c) mean value of the thickness;
- d) parameter set used for measurement of flexural properties
- e) indication of which side was measured (compression and / or extension)
- f) average of bending force in mN with three significant digits
- g) any deviations from the standard

Annex A
(informative)

Sources of apparatus

Examples of suitable products available commercially are giving below. This information is given for the convenience of user of this International Standard and does not constitute an endorsement by ISO of these products.

A suitable apparatus is manufactured for example by:

FRANK-PTI GmbH, Auf der Aue 1, 69488 Birkenau, Germany